

**45 Class**  
2-cycle engine

**70 Class**  
4-cycle engine

*Or Electric equivalent*

**YAKOVLEV  
YAK-52**



**INSTRUCTION MANUAL / Montageanleitung**

*All balsa, plywood construction and almost ready to fly*



**SPECIFICATIONS**

Wingspan	60.6 in.
Length	43.9 in.
Electric Motor	870 Watt (PULSAR 60)
Glow Engine	.46 2-T / .70 4-T
Radio	5 Channel / 5 Servos

**TECHNISCHE DATEN**

Spannweite	1540mm
Länge	1117mm
Elektroantrieb	870 Watt (PULSAR 60)
Verbrennerantrieb	7.5cc 2-T / 11cc 4-T
Fernsteuerung	5 Kanal / 5 Servos



**WARNING!** This radio controlled model is NOT a toy. If modified or flown carelessly it could go out of control and cause serious human injury or property damage. Before flying your airplane, ensure the air field is spacious enough. Always fly it outdoors in safe areas and seek professional advice if you are unexperienced.

**ACHTUNG!** Dieses ferngesteuerte Modell ist KEIN Spielzeug! Es ist für fortgeschrittene Modellflugpiloten bestimmt, die ausreichende Erfahrung im Umgang mit derartigen Modellen besitzen. Bei unsachgemäßer Verwendung kann hoher Personen- und/oder Sachschaden entstehen. Fragen Sie in einem Modellbauverein in Ihrer Nähe um professionelle Unterstützung, wenn Sie Hilfe im Bau und Betrieb benötigen. Der Zusammenbau dieses Modells ist durch die vielen Abbildungen selbsterklärend und ist für fortgeschrittene, erfahrene Modellbauer bestimmt.

# REQUIRED FOR OPERATION (Purchase separately) BENÖTIGTE KOMPONENTEN FÜR DEN ABFLUG (Nicht enthalten)

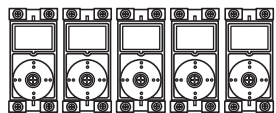
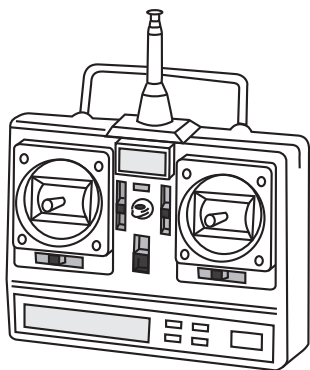

Minimum 5 channel radio for airplane with 5 servos  
.Motor control x1 .Aileron x2  
.Elevator x1 .Rudder x1



10.5x6 for .40 - 2 cycle engine  
11x6 for .46 - 2 cycle engine  
12x6 for .60 - 4 cycle engine  
12x7 for .70 - 4 cycle engine  
13x6 for Quantum 4120/05

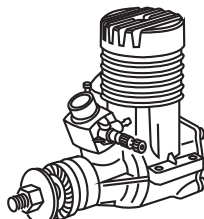

.46 ~ .50 - 2 cycle

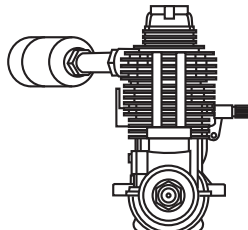

.60 ~ .70 - 4 cycle



Silicone tube

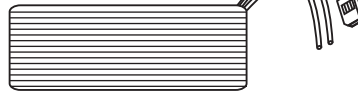

Li-Po Battery, 14.8V, 4000mAH, 80A



Retract servo x1

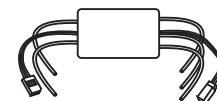

Phoenix-60 Brushless Motor Control

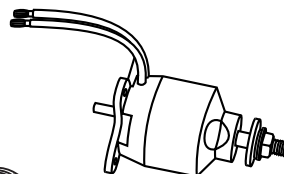

Quantum 4120/05 Brushless Motor or equivalent.

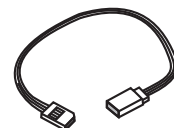

Extension for aileron servo, retract servo.

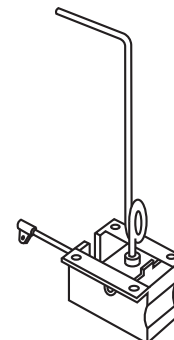

Retract landing gear VQAR04



Linkage Stopper x2 (for retract servo)

## GLUE (Purchase separately)



Silicon sealer

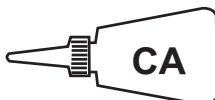

Cyanoacrylate Glue



Epoxy Glue ( 5 minute type)



Epoxy Glue (30 minute type)

## TOLLS REQUIRED (Purchase separately)

Hobby knife 

Phillip screw driver 

Hex Wrench 

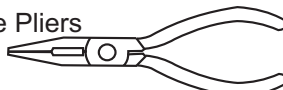
Needle nose Pliers 

Scissors 

Awl 

Sander 

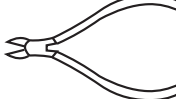
Wire Cutters 

Masking tape - Straight Edged Ruler - Pen or pencil - Rubbing alcohol - Drill and Assorted Drill Bits

If exposed to direct sunlight and/or heat, wrinkles can appear. Storing the model in a cool place will let the wrinkles disappear. Otherwise, remove wrinkles in covering film with a hair dryer, starting with low temperature. You can fix the corners by using a hot iron.

Bei Sonneneinstrahlung und/oder Wärme kann die Folie erschlaffen bzw. Falten entstehen. Verwenden Sie ein Warmluftgebläse (Haartrockner) um evtl. Falten aus der Folie zu bekommen. Die Kanten können Sie mit einem Bügeleisen behandeln. Nicht zuviel Hitze anwenden !

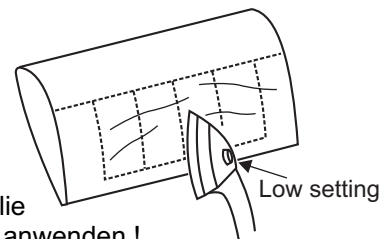



Symbols used throughout this instruction manual, comprise:

 Drill holes using the stated size of drill (in this case 1.5 mm Ø)

 Take particular care here

 Hatched-in areas: remove covering film carefully

 Check during assembly that these parts move freely, without binding

 Use epoxy glue

 Apply cyano glue

 Assemble left and right sides the same way.

 Not included. These parts must be purchased separately

 Löcher bohren mit dem angegebenen Bohrer (hier 1,5 mm)

 Hier besonders aufpassen

 Schraffierte Stellen, Bespannfolie vorsichtig entfernen

 Während des Zusammenbaus immer prüfen, ob sich die Teile auch reibungslos bewegen lassen

 Epoxy-Klebstoff verwenden

 Sekundenkleber auftragen

 Linke und rechte Seite wird gleichermaßen zusammgebaut

 Nicht enthalten. Teile müssen separat gekauft werden.

Read through the manual before you begin, so you will have an overall idea of what to do.

## CONVERSION TABLE

1.0mm = 3/64"	3.0mm = 1/8"	10mm = 13/32"	25mm = 1"
1.5mm = 1/16"	4.0mm = 5/32"	12mm = 15/32"	30mm = 1-3/16"
2.0mm = 5/64"	5.0mm = 13/64"	15mm = 19/32"	45mm = 1-51/64"
2.5mm = 3/32"	6.0mm = 15/64"	20mm = 51/64"	

# 1- Retract landing gear / Fahwerk

Trial fit the push rod into the wing. Join the pushrod to the retract gear arm and trial fit the retract into the wing.

After checking that the retract works smoothly, fix the retract on the wing with 3x12mm screws

**L/R**

Retract pushrod  
Fahrwerkenlenkgestänge

Steel clevis	.....2
3x12mm screw	.....8

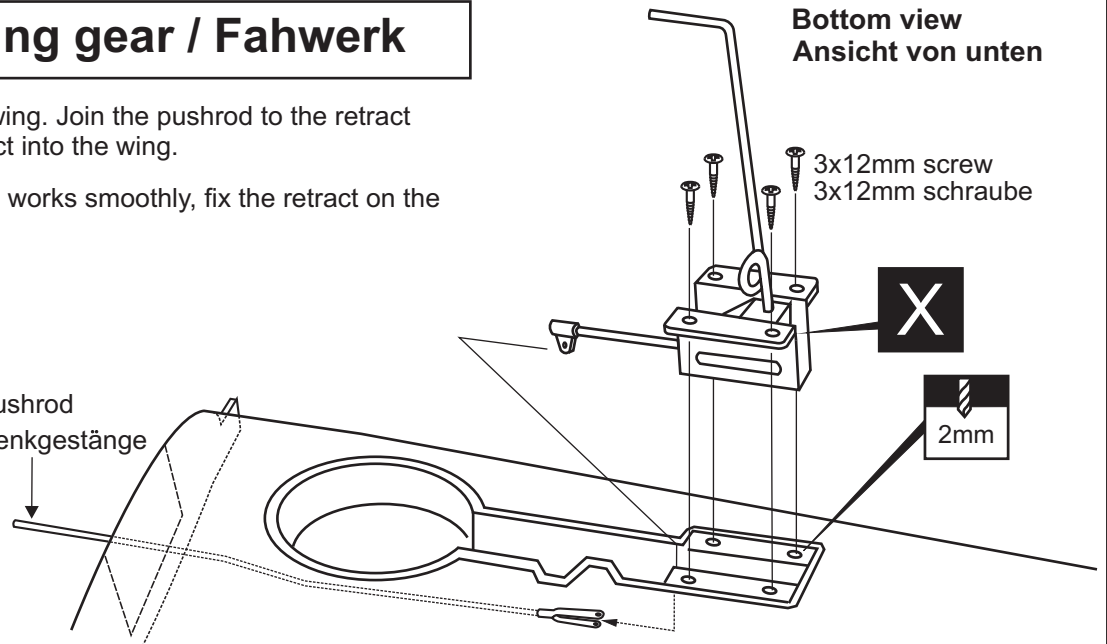

Bottom view  
Ansicht von unten

3x12mm screw  
3x12mm schraube

2mm

# 2- Aileron servo / Querruder servo

Bottom view / Ansicht von unten

Aileron extension cord  
Servoverlängerungskabel

Plastic control horn

.....2
2x20mm screw
.....4

Top view / Ansicht von Oben

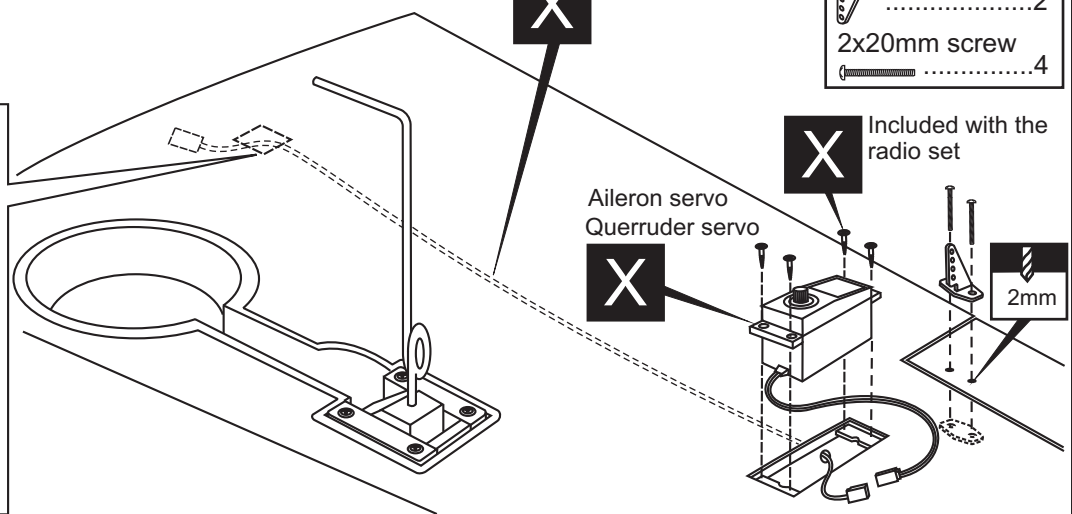
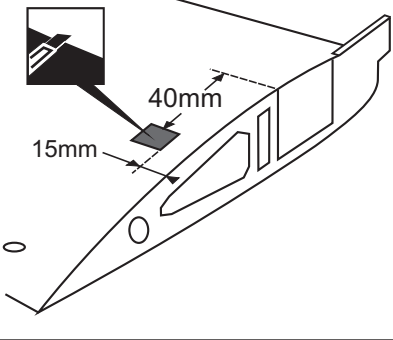

Included with the radio set

Aileron servo  
Querruder servo

2mm

# 3- Joining the wing / Fläche

Top view / Ansicht von Oben

Use epoxy glue to bury the opening  
Nehmen Sie Epoxykleber, um die Tragflächen fest miteinander zu Verbinden und streifen Sie den herausquellenden Kleber nach dem Verbinden mit einem fusselfreien Tuch SOFORT ab!



Secure one end of the aileron extension cord with adhesive tape

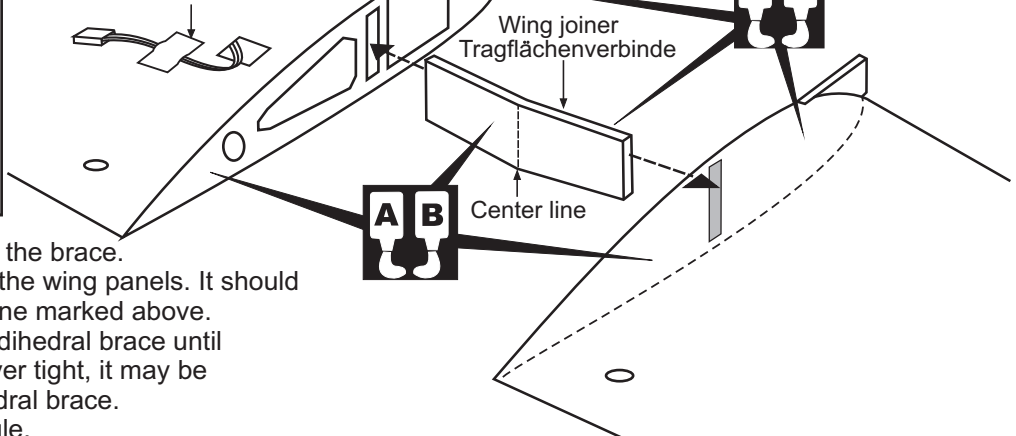

- 1- Using a pencil, mark the center of the brace.
- 2- Trial fit the wing joiner into one of the wing panels. It should insert smoothly up to the center line marked above.
- 3- Slide the other wing half onto the dihedral brace until the wing panel meet. If the fit is over tight, it may be necessary to lightly sand the dihedral brace.
- 4- Check for the correct dihedral angle.
- 5- Mix approximately 30 minute epoxy and apply a generous amount of epoxy into the wing joiner cavity of one wing half.
- 6- Coat one half of the dihedral brace with epoxy up to the center line. Install the epoxy-coated side of the dihedral brace into the wing joiner cavity up to the center line, marking sure that the "V" of the dihedral brace is positioned correctly
- 7- Do the same way with the other wing half.
- 8- Carefully slide the wing halves together, ensuring that they are accurately aligned. Firmly press the two halves together, allowing the excess epoxy to run out. Clear off the excess epoxy.

**WARNING:** Please do not clean off the excess epoxy on the wing with strong solvent or pure alcohol, only use kerosene to keep the colour of your model not fade.

## 4- Servo mount / Servohalterung

Schneiden Sie etwas Folie weg  
Cut away only the covering

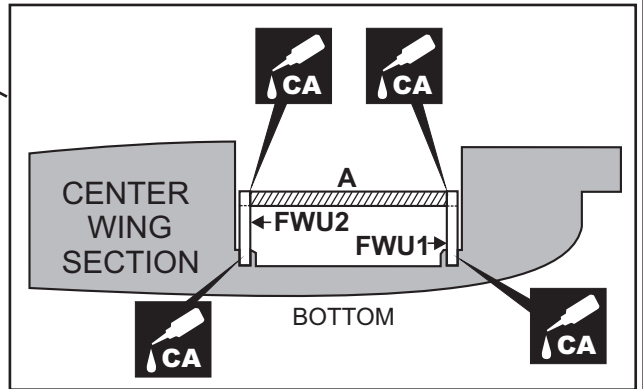
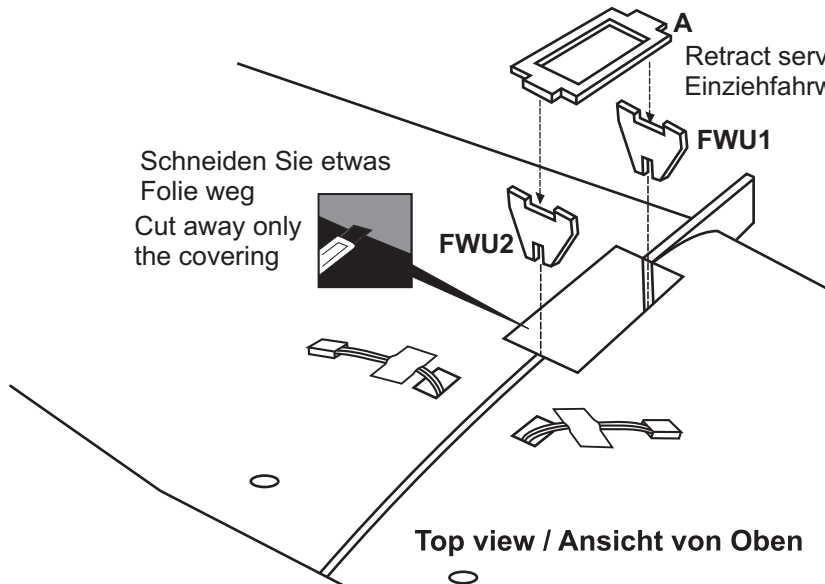

## 5- Retract servo / Einziehfahrwerk servo

Install the retract servo onto the retract servo mount and secure it in place with four screw (included with radio set).

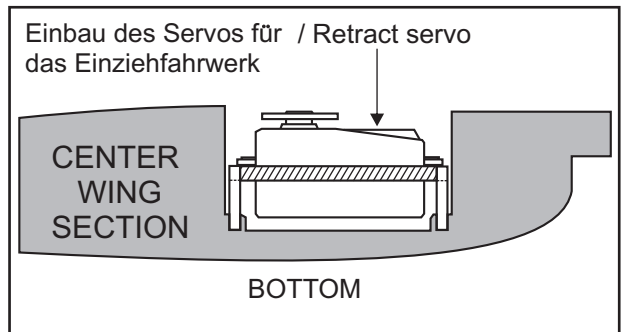
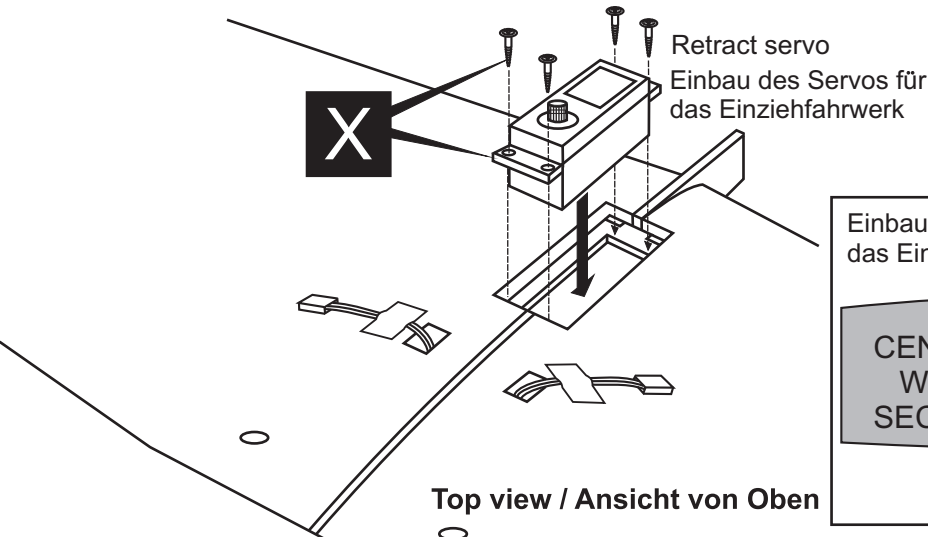

## 6- Linkages / Ruderanlenkung

Instruction how to build in the retracting landing gear (This Gear is OPTIONAL)

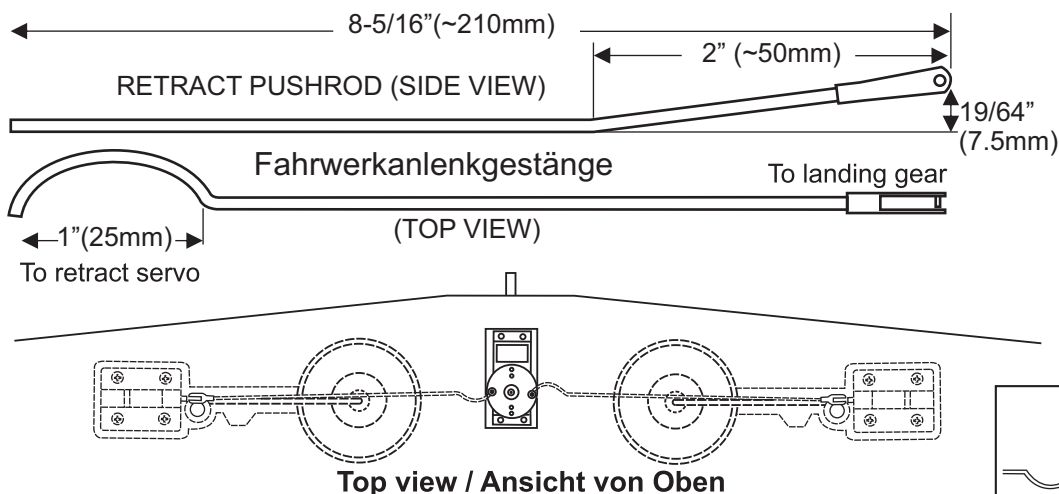

Einbauhilfe bei Anbringen eines Einziehfahrwerks (Optional bestellbar; nicht im Baukasten enthalten!)

With the retract and retract servo in the retracted position, mark the position where each of the pushrod will attach to the servo arm, a small piece of masking tape works well for this. Cut off the excess length each rod.

Link the servo and retract gear arm with push rod. Be sure to adjust the stroke so that the landing gear locks in both up and down position.

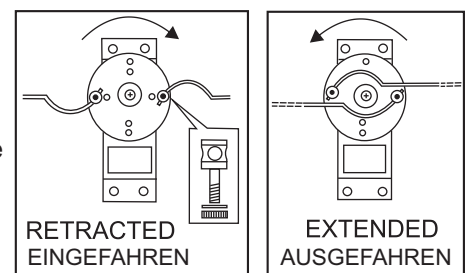

## 7- Fixed gear / Landegestänge

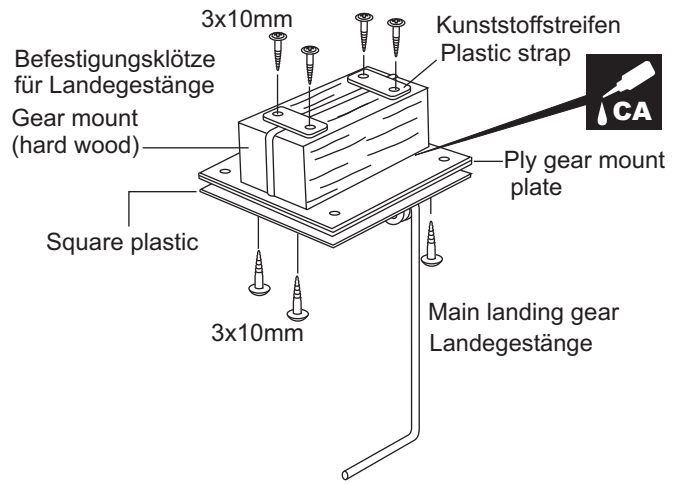
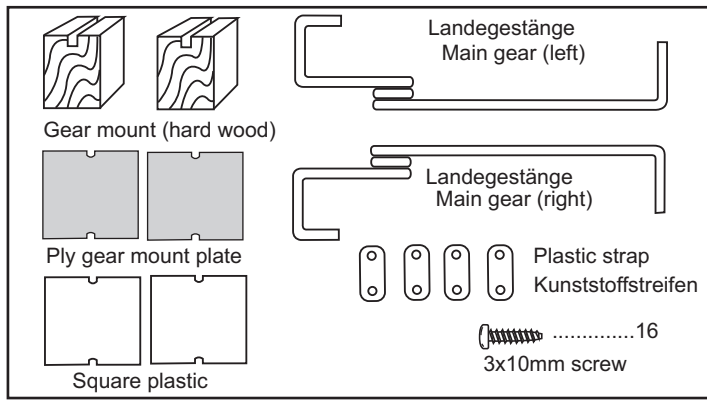

## 8- Fixed gear / Landegestänge

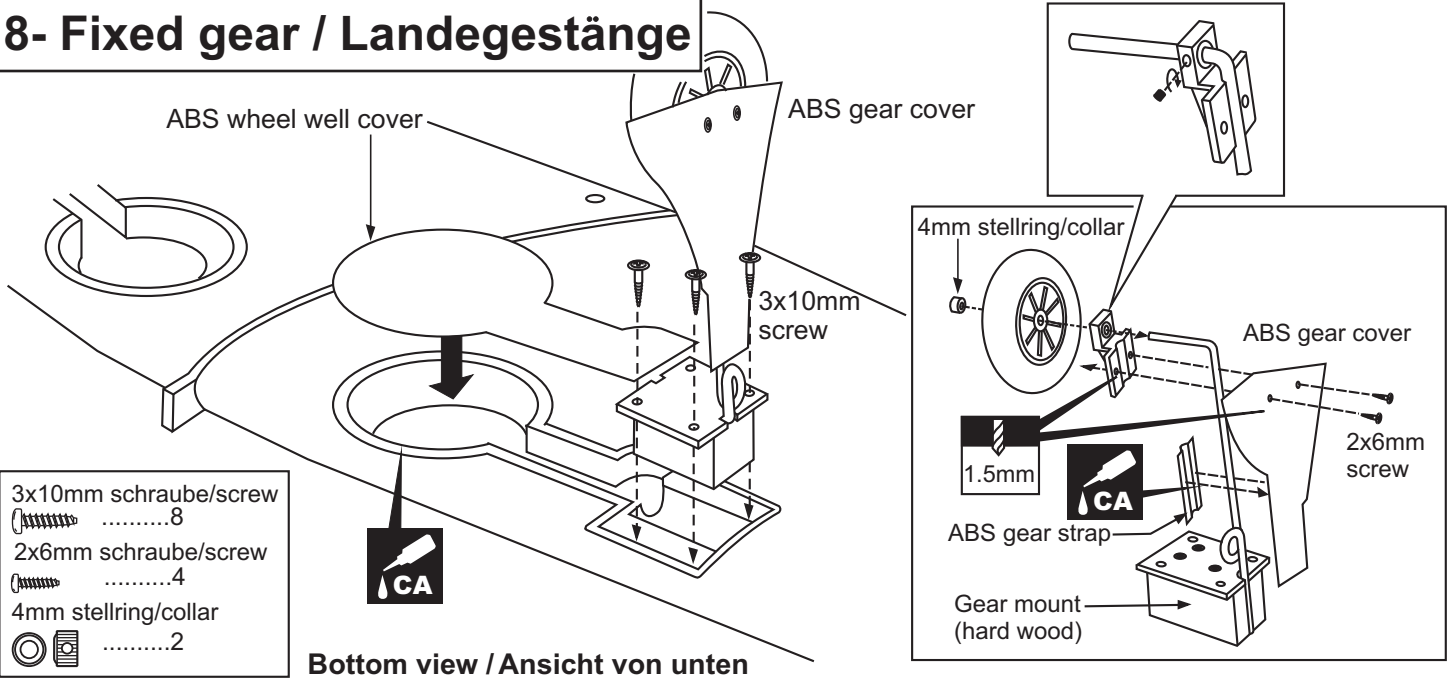

## 9- Electric retract landing gear / Einziehfahrwerk

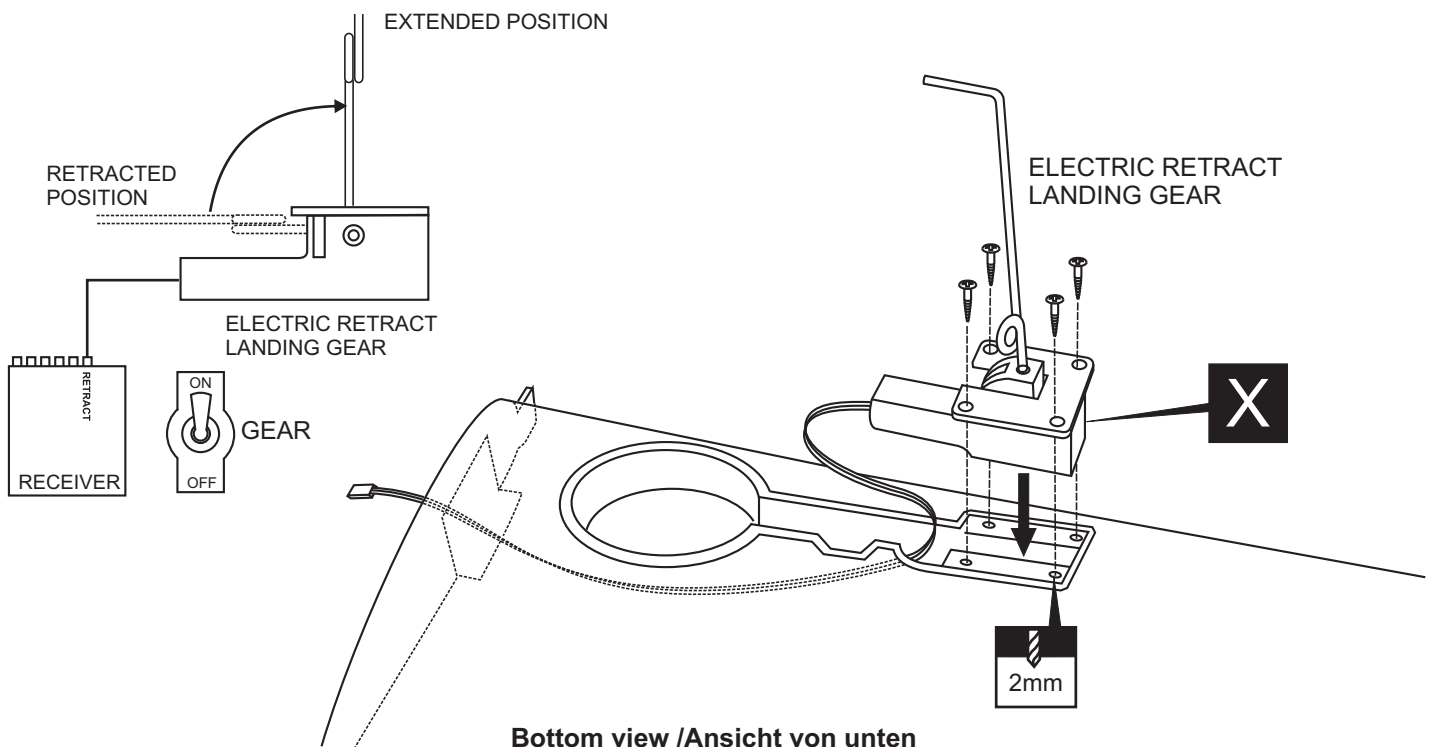

## 10- Horizontal stabilizer / Höhenruder

- 1-Trial fit the horizontal stabilizer in place . Check the alignment of the horizontal stabilizer. When you are satisfied with the alignment, use a pencil to trace around the top and bottom of the stabilizer where it meets the fuselage.
- 2-Remove the horizontal stabilizer from the fuselage. Using the sharp hobby knife, carefully cut away the covering inside the lines which were marked above.
- 3-Spread epoxy (30 minute) onto the top and bottom of the horizontal stabilizer along the area where the covering was removed and to the fuselage where the horizontal stabilizer mounts.
- 4-Install the horizontal stabilizer into the fuselage and adjust the alignment as described in step 1
- 5-Wipe off any excess epoxy using a paper towel and kerosene, do not use strong solvent or pure alcohol to keep the colour of your model not fade. Allow the epoxy to cure before proceeding to next step.

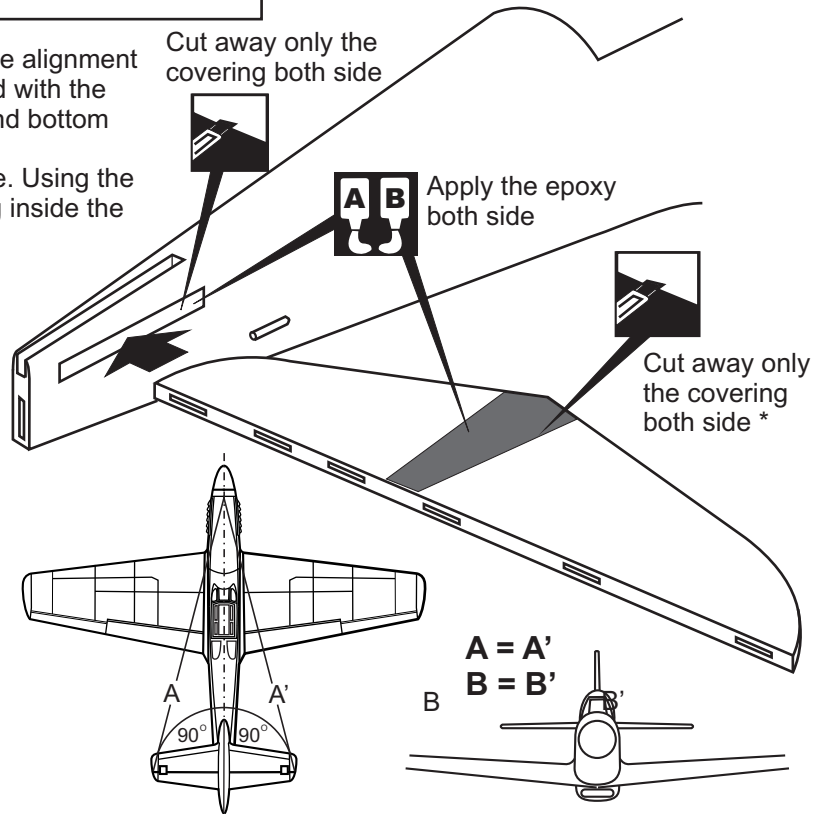

Vergewissern Sie sich, sauber geklebt zu haben. Andernfalls können Probleme mit der Flugeigenschaft auftreten!

**\* WARNING:** When removing any covering from the airframe, please ensure that you secure the cut edge with CA or similar cement. This will ensure the covering remain tight.

## 11- Vertical stabilizer / Höhenleitwerk

- 1-Trial fit the vertical stabilizer in place . Check the alignment of the vertical stabilizer. When you are satisfied with the alignment, use a pencil to trace around the right and left of the stabilizer where it meets the fuselage.
- 2-Remove the vertical stabilizer from the fuselage. Using the sharp hobby knife, carefully cut away the covering inside the lines which were marked above.
- 3-Spread epoxy (30 minute) onto the right and left and bottom of the vertical stabilizer along the area where the covering was removed and to the fuselage where the vertical stabilizer mounts.
- 4-Install the vertical stabilizer into the fuselage and adjust the alignment as described in step. 1

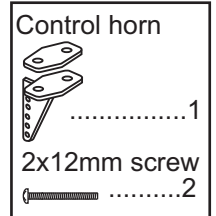
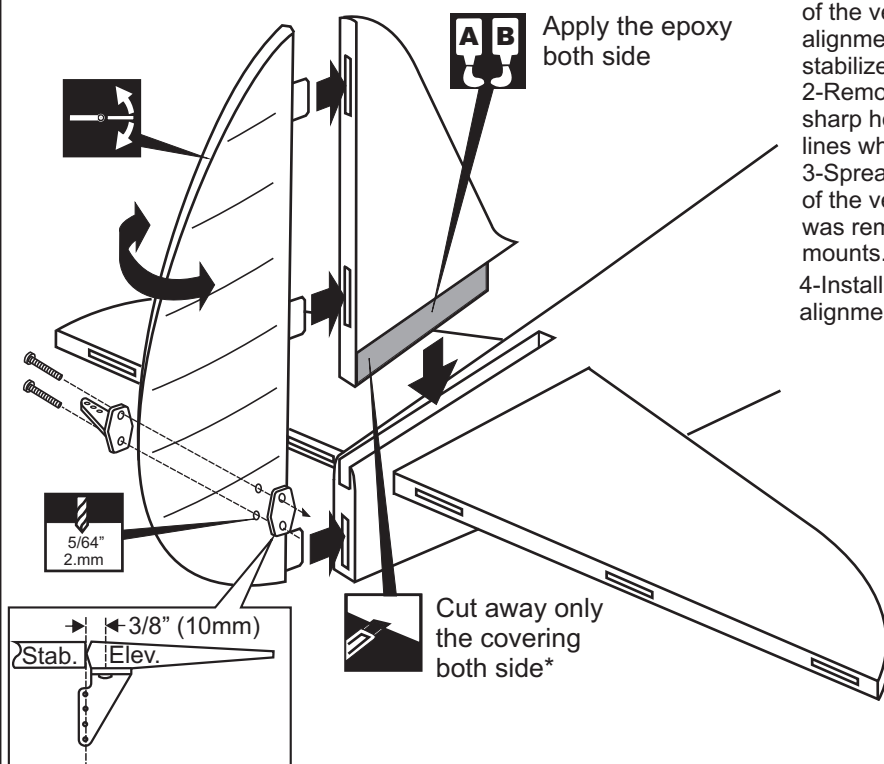

B = B'  
C = C'

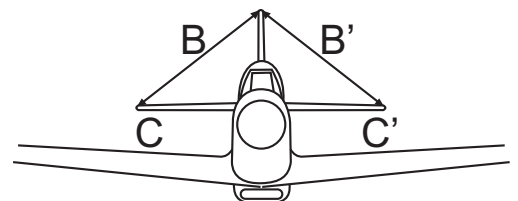

**Securely glue together. If coming off during flight, you lose control of your air plane!**

**\* WARNING:** When removing any covering from the airframe, please ensure that you secure the cut edge with CA or similar cement. This will ensure the covering remain tight.

## 12- Elevator / Höhenruder

Apply a thin layer of machine oil or petroleum jelly to only the pivot point of the hinges on the elevator, then push the elevator and its hinges into the hinge slots in the trailing edge of the horizontal stabilizer.

When satisfied with the and alignment, hinge the elevator to the horizontal stabilizer using 5 minute epoxy. Make sure to apply a thin layer of epoxy to the top and bottom of both hinges and to inside the hinge slots. Repeat the previous procedures to hinge the second elevator to the other side of the horizontal stabilizer.

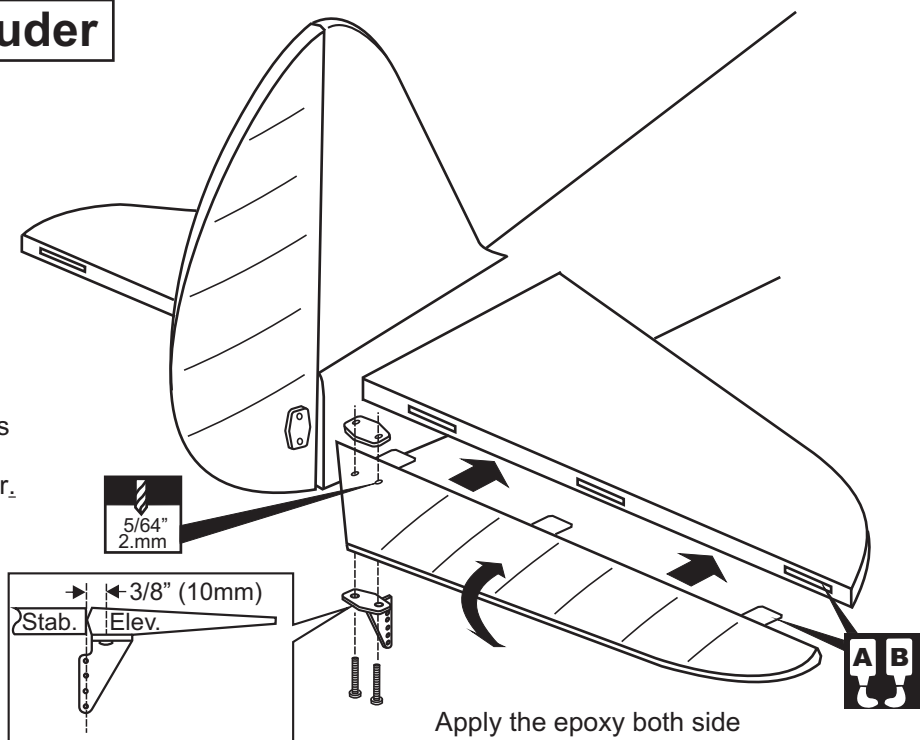

*Securely glue together. If coming off during flight, you lose control of your air plane!*

**Vergewissern Sie sich, sauber geklebt zu haben. Andernfalls können Probleme mit der Flugeigenschaft auftreten!**

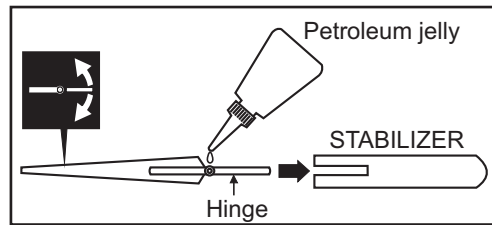
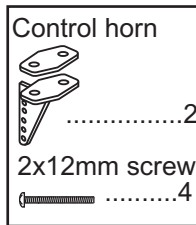

## 13- Tail gear / Heckspornrad

Bottom view / Ansicht von unten

- 1/8x15/32" (3x12mm) screw
- .....2
- Tail gear horn
- .....1
- 5/64" (2mm) collar
- .....1

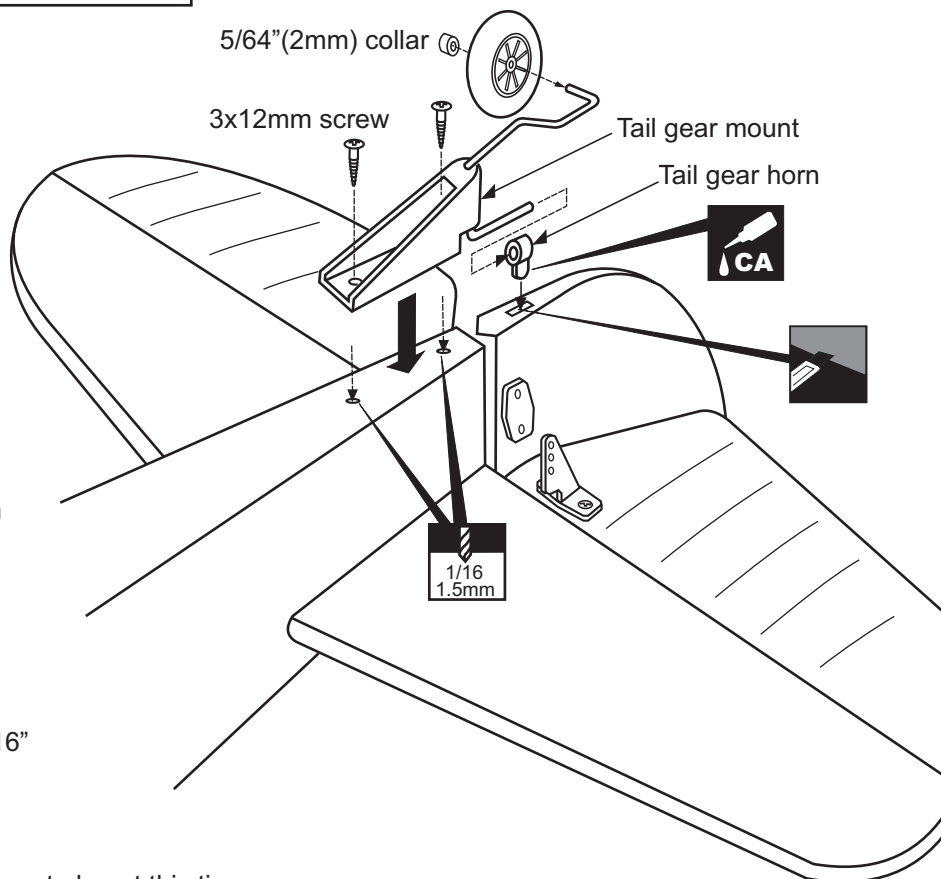

1-Place the tail gear mount on the bottom of the fuselage as show, mark the mounting hole positions with a pencil.  
2-Remove the tail gear mount from the fuselage, Drill the two mounting holes as marked.

3-Cut a 5/64" (2mm) wide slot which is 5/16" (8mm) length and 5/16" (8mm) depth on the bottom of the rudder as shown.

4-Trial fit the tail gear horn into the slot. Do not glue at this time.  
5-Slide the tail gear into the tail gear horn. Secure the tail gear mount in place using the two 3x12mm screw.  
6-Secure the tail gear horn in place using CA glue as shown.

# 14- Fuel tank / Kraftstofftank

Magnetic canopy

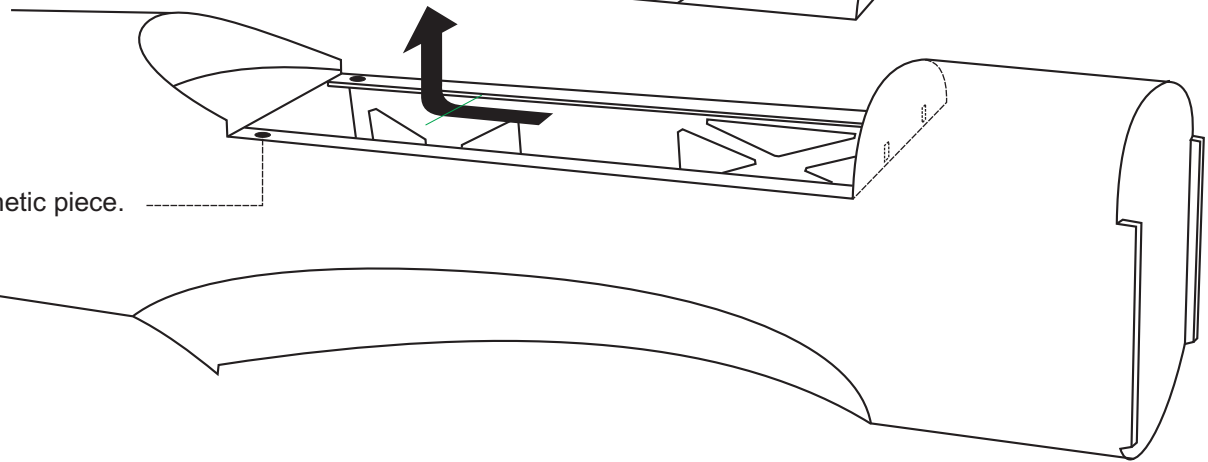
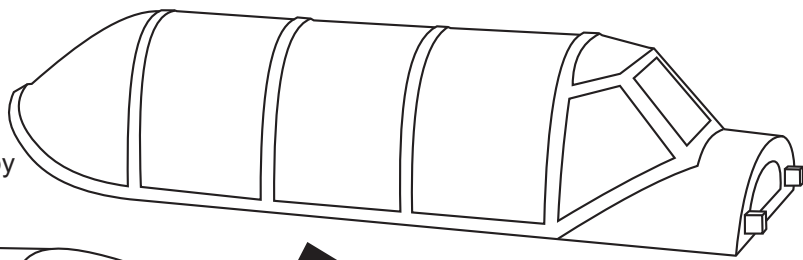

Magnetic piece.

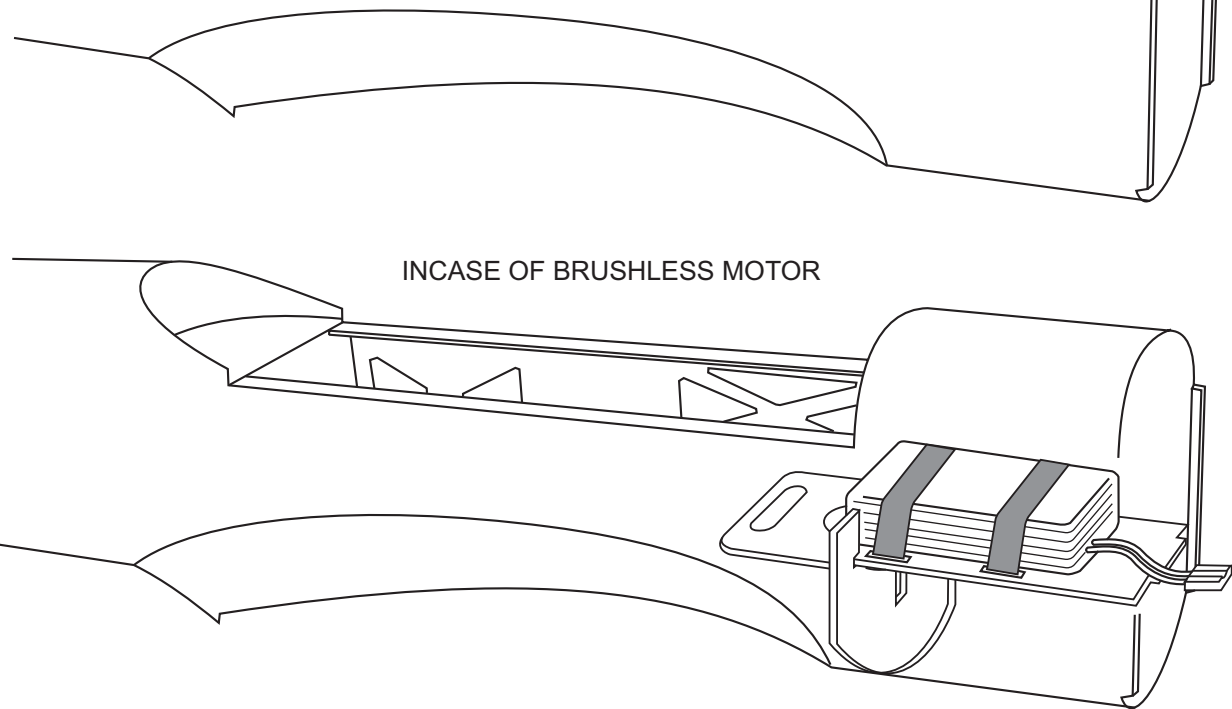

INCASE OF BRUSHLESS MOTOR

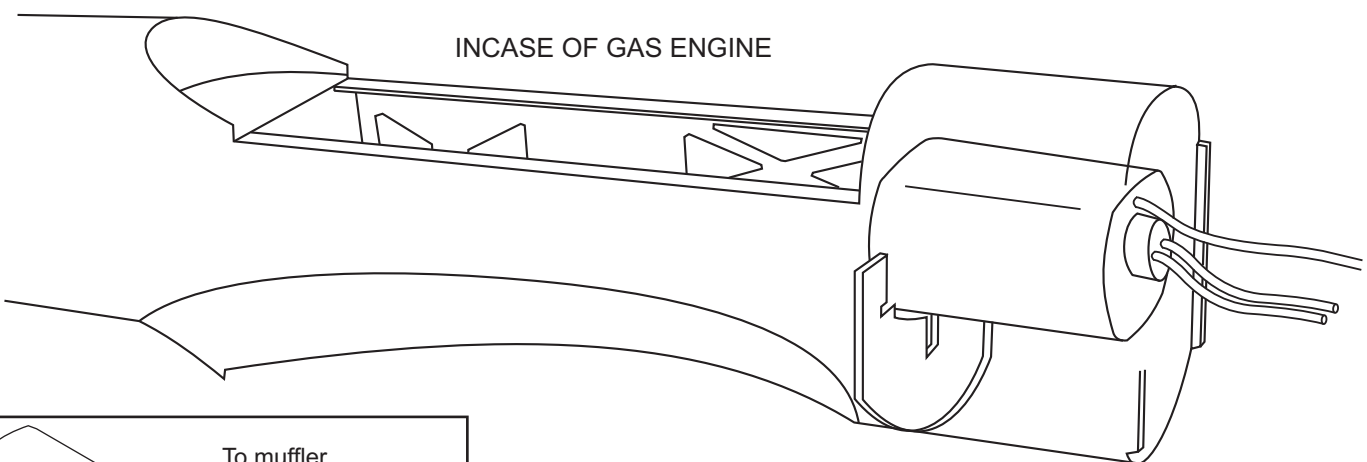

INCASE OF GAS ENGINE

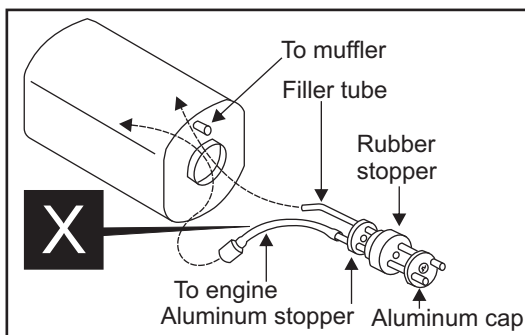

After confirming the direction . Insert and tighten the screw.

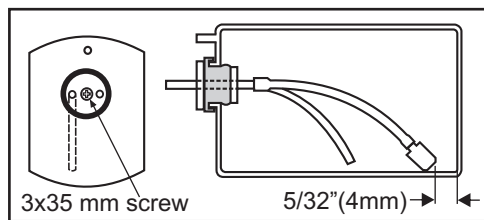

Push the fuel tank forward until there are no gaps between the tank and firewall.



# 15- Electric Motor / Elektromotor

- Using a plywood motor mounting plate as a template, mark the fire wall where the four holes are to be drilled (1).
- Remove the plywood motor mounting plate and drill a 13/64" (5mm) hole through the fire-wall at each of the four marks marked (2).
- Using an aluminum motor mounting plate as a template, mark the plywood motor mounting plate where the four holes are to be drilled (3).
- Remove the aluminum motor mounting plate and drill a 1/8" (3mm) hole through the plywood at each of the four marks marked (4).

FRONT-VIEW

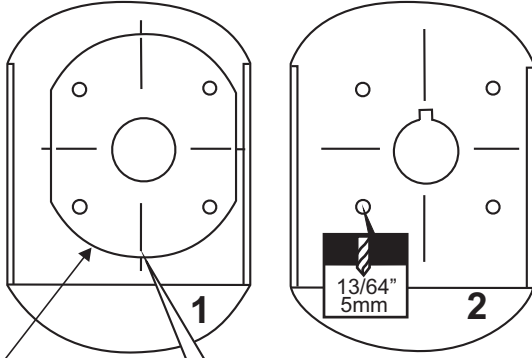

Plywood motor mounting plate (2pcs)

! Align the mark on the plywood motor mount with the mark on the fuselage.

Aluminum motor mounting plate

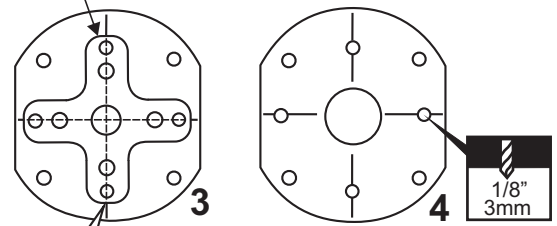

! Align the mark on the plywood motor mount with the center lines on aluminum motor mount.

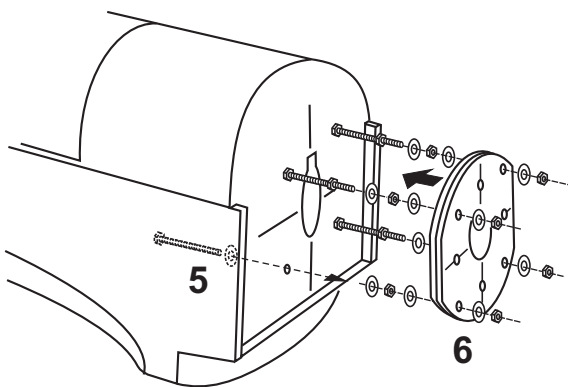

- Push the four 5x70mm bolts through the fire-wall as shown (5).
- Reposition the plywood motor mounting plate (2pcs) and secure it in place with eight 5mm nuts and washers (6).  
Note: B=B' (Side-view) and A=A' (Top-view)

- Attach the aluminum motor mounting plate on to the motor and secure it in place with four screws ( included with motor set) (7).
- Attach the motor on to the plywood motor mounting plate and secure it in place with four 3x15mm (1/8x19/32") screws(8).

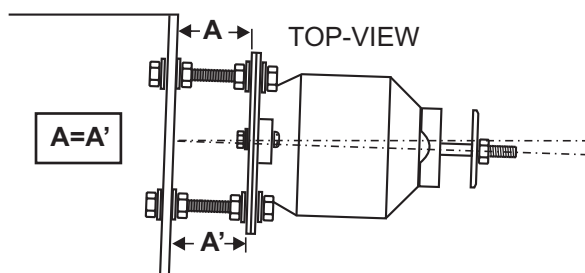
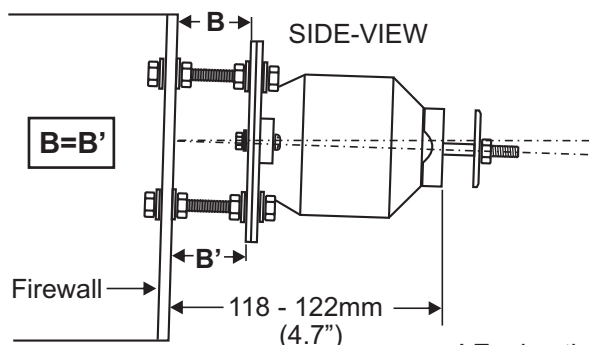
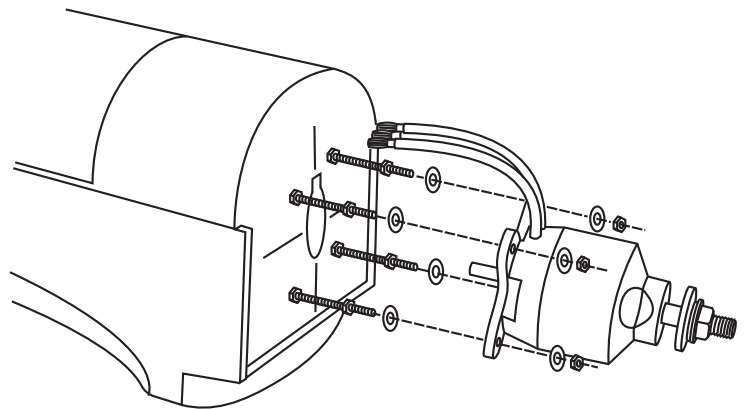
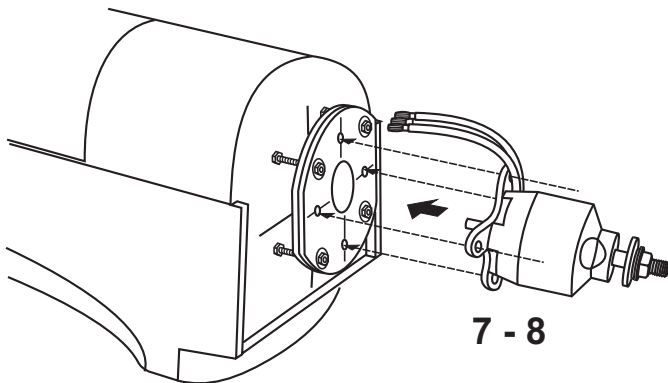

! Engine thrust on balk head is already adjust at factory

- 5x70mm.....4
- 5mm nut.....12
- 5mm washer...16
- 3mm screw/nut...4

## 16- Engine mount / Motorträger

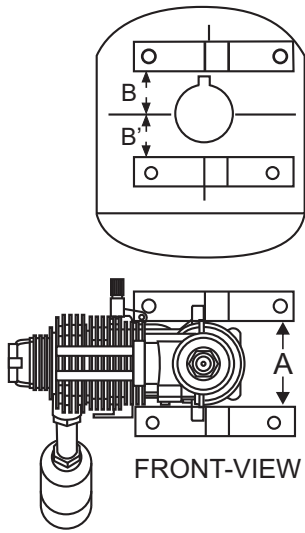

! Engine thrust on balk head is already adjust at factory

B=B'

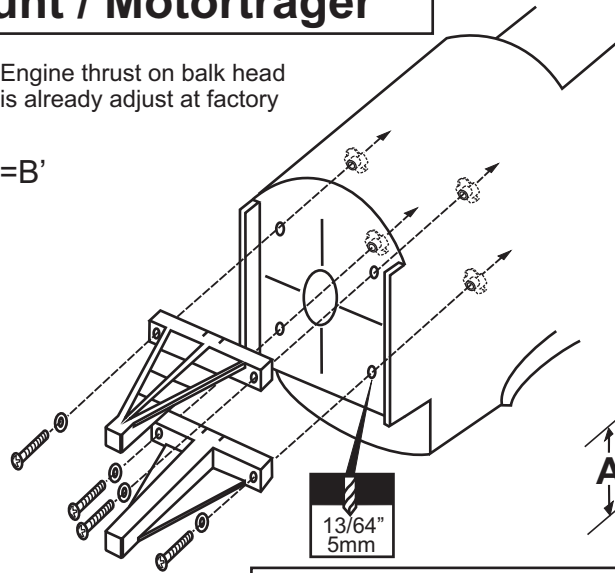

! Align the mark on both mounts with the center mark on the fire wall

! Align the engine center with fire wall marked line

4x25mm screw .....4

Blind-nut .....4

4mm washer .....4

## 17- Engine (two stroke) / 2T Motor

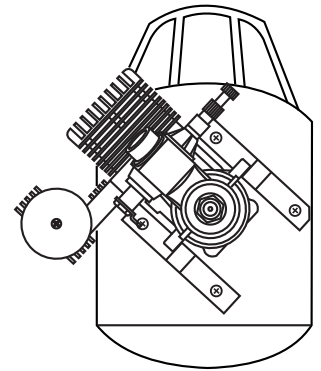
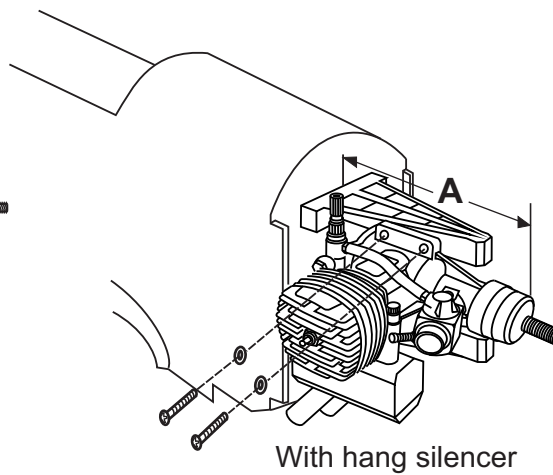
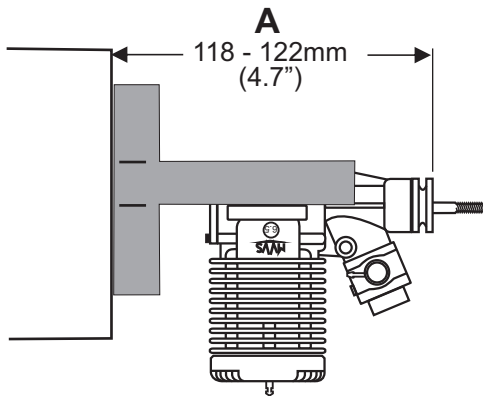

With side silencer

3x25mm screw  
Nut  
.....4

Determine the angle for the engine mounts so the muffler will not contact the fuselage

## 18- Engine (four stroke) / 4T Motor

Top view / Ansicht von Oben

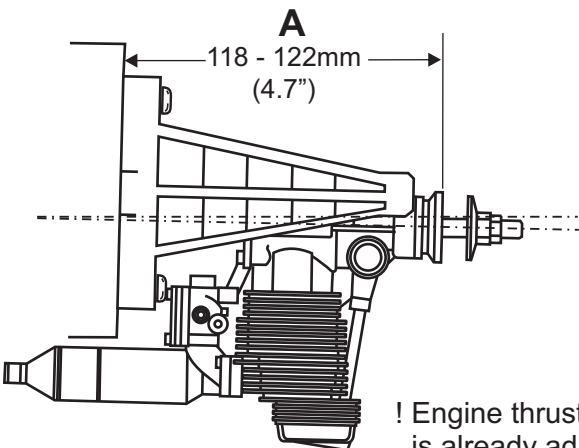

! Engine thrust on balk head is already adjust at factory

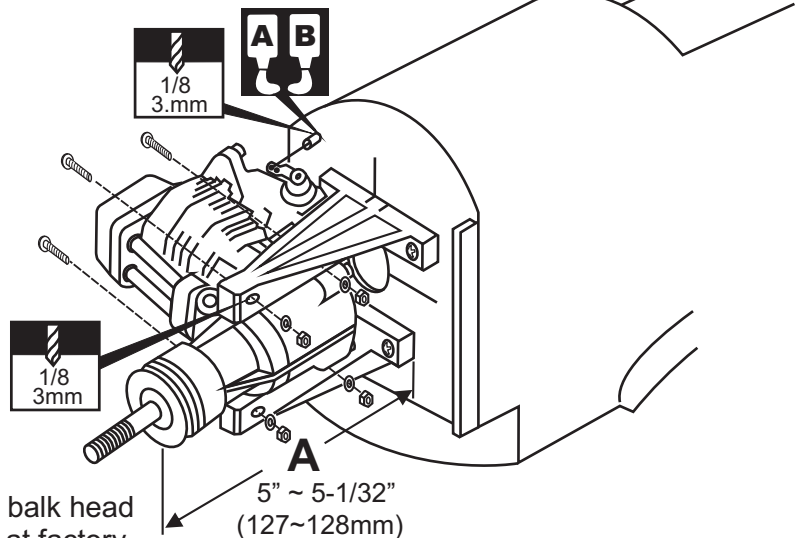

# 19- Cowling installation Motorhaube

1 Position the engine on to the engine mounts so the distance from the prop hub to the fire wall is 120mm.

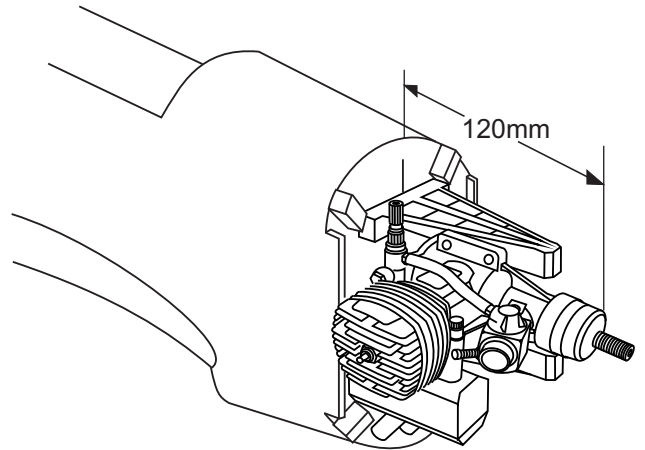

2 Insert the cowl on to the fuselage so the distance from the fire-wall to the front of the cowl is 116 - 118mm.  
Using a pencil or felt tipped pen trace around the cowl where it meet the fuselage.

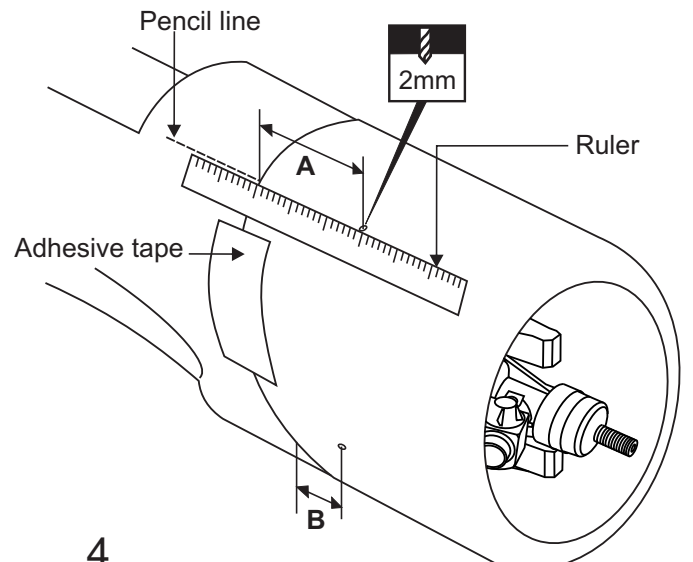
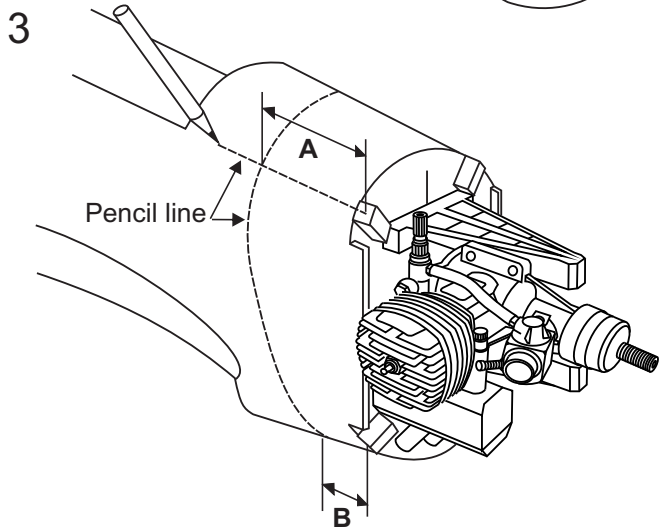
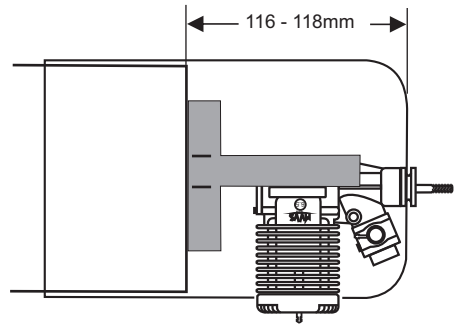
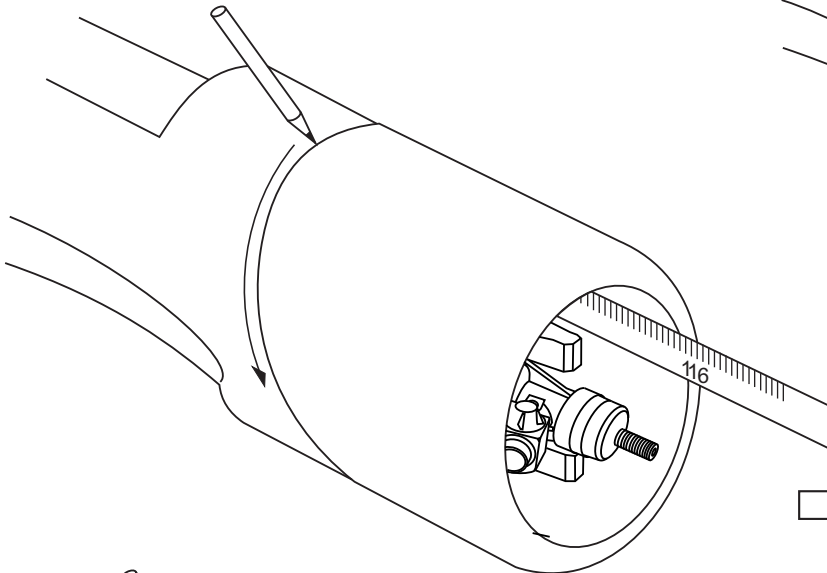

4 Again, insert the cowl on to the fuselage so the rear edge of the cowl meet the pencil line and secure it in place with the adhesive tape.  
Drill four 2mm holes on the cowl as shown.

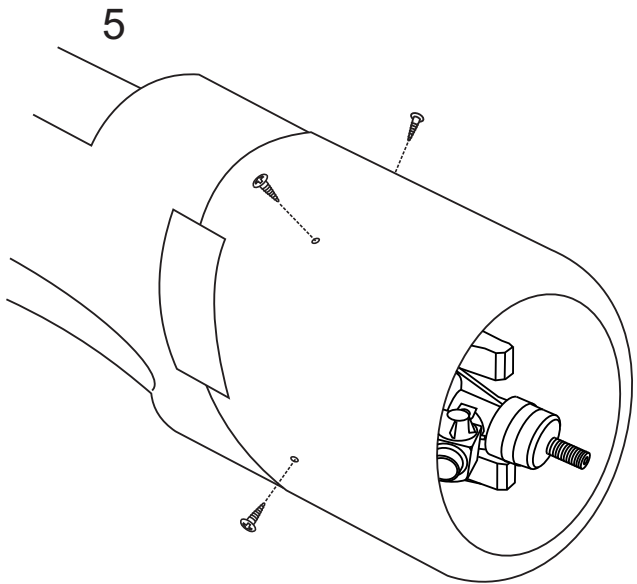

## 20- Air scoop / Ölkühlerattrappe

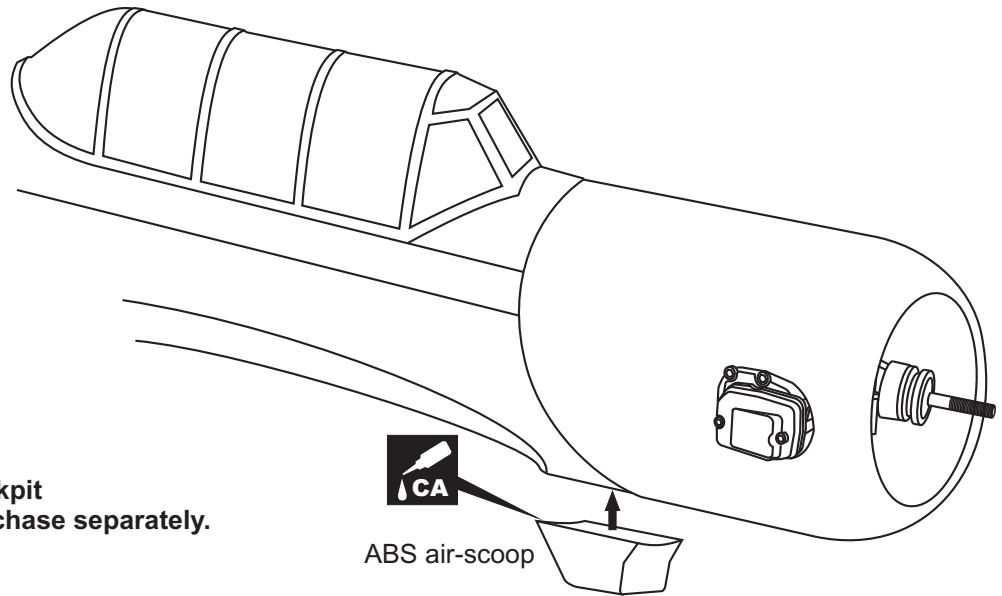

**Note: Only one pilot in cockpit  
The second pilot must purchase separately.  
(VQAP09)**

ABS air-scoop

## 21- Servo installation

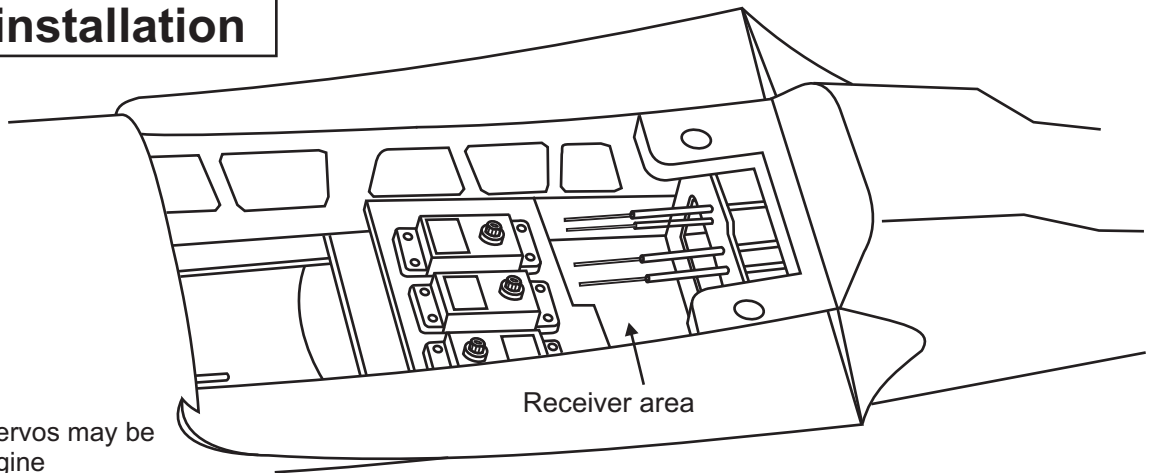

**NOTE:** Place of the servos may be change depend of engine  
(Four-stroke or two-stroke engine)

Bottom view / Ansicht von unten

## 22- Linkages / Ruderanlenkung

Bottom view / Ansicht von unten

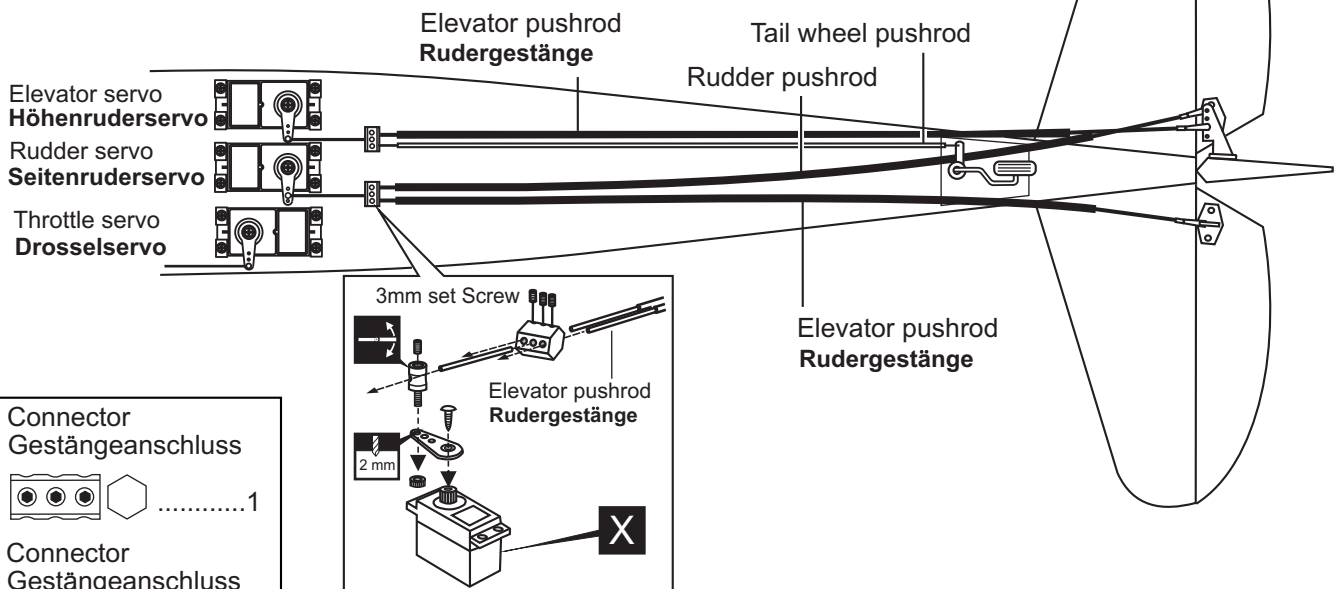

Connector  
Gestängeanschluss

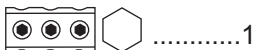

.....1

Connector  
Gestängeanschluss



.....3

## 23- Decor / Aufkleber

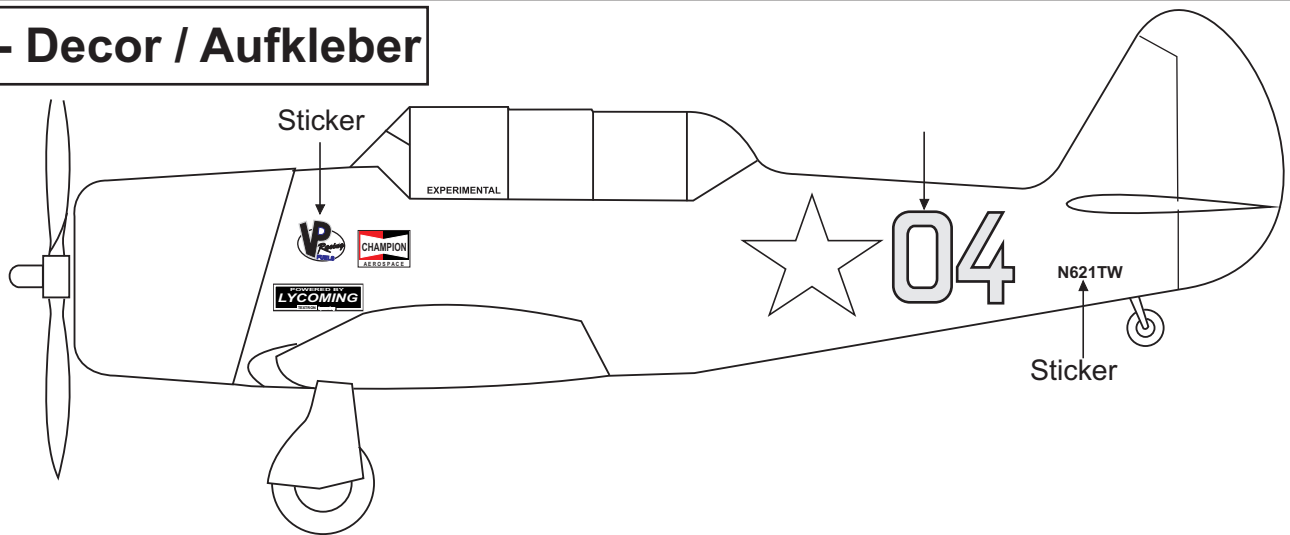

Note: Cut out the stickers and apply them in the proper area. Do not peel the backing paper off all at once. Peel off one corner of the backing and cut off with scissors. Arrange sticker on model and when satisfied adhere the corner without backing.

Carefully peel back the rest of the backing while at the same time adhering the rest of the sticker.

Try not to make air bubbles, if there are some, carefully puncture sticker (center of bubble) but not model surface with the tip of the knife or sharp pin and squeeze out the air. At curves stretch sticker and apply a little heat so that no creases occur. Cut off the excess that is produced.

**WARNING:** Please do not clean your model with pure alcohol or strong solvent, only use liquid soap with water or use glass cleaner to clean on surface of your model to keep the colour not fade.

*All details are subject to change without notice !*

*Technische Änderungen und Irrtümer vorbehalten !*

## 24- Balance / Schwerpunkt

Note: Adjust the location of the battery pack to achieve this C.G. location.

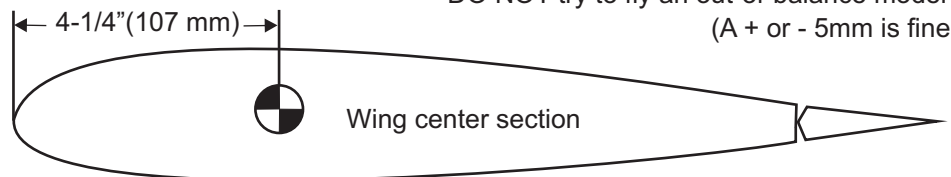

DO NOT try to fly an out-of-balance model !  
(A + or - 5mm is fine)

## 25- Control surface / Ruderausschläge

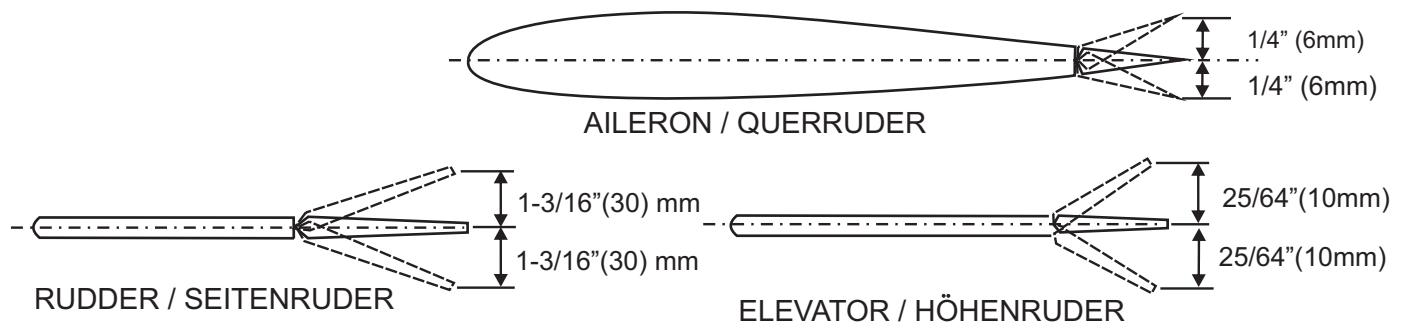

**IMPORTANT:** Flying your model at these throws will provide you with the greatest chance for successful first flights. If, after you have become accustomed to the way the Yak flies, you would like to change the throws to suit your taste that is fine. However, too much control throw could make the model difficult to control, so remember, "more is not always better".